

INFINITE COLOR MIXING

SUPERIOR OPTICS

**PROJECTS IMAGES,
LOGOS AND PATTERNS**

**QUIET OPERATION—NO
FANS**

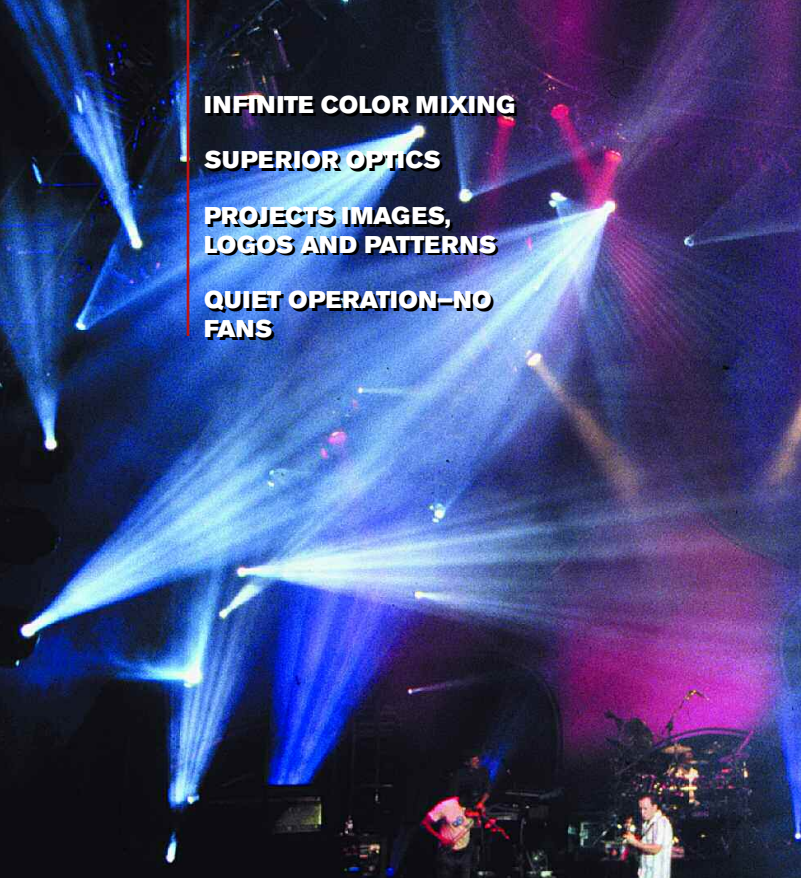

STUDIO SPOT CMY

AUTOMATED LUMINAIRE

The **Studio Spot® CMY** is a hard-edged moving yoke light that features graduated color wheels to provide smooth, **INFINITE CMY COLOR MIXING**. Its superior optics also offer the user a range of options from beam-shaping effects to **LITHOPATTERNS® PROJECTION** of standard or custom images, logos or patterns for near photo-quality projection. Ten user-selectable gobos/effects can be installed into two rotating gobo wheels for a wide variety of pattern or logo projections.

The Studio Spot CMY uses an MSR 575/2 lamp with 6200° K color temperature. An **OPTIONAL MSD 575 LAMP** with enhanced lamp life is available for architectural applications. Other important optical features include remote focus, variable speed iris, smooth mechanical dimming, plus a shutter for blackout and strobe effects. Studio Spot CMY also features a universal power supply and power factor correction. The luminaire is convection cooled and uses no fans for quiet operation.

Whether it's used on the road or on a building, the Studio Spot CMY's **SUPERIOR OPTICS, PAN AND TILT MOVEMENT AND SOPHISTICATED STYLING** make it the perfect high-precision instrument for a wide range of applications.



STUDIO SPOT CMY NOW AVAILABLE WITH ZOOM!
see back for more information



STUDIO SPOT[®] CMY

STUDIO SPOT CMY NOW AVAILABLE WITH ZOOM!

- 18° to 30° zoom covers the range of the most popular fixed lenses
- No loss of light output from standard lenses
- Replaces variable frost function
- Available both as complete fixture and as an upgrade
- Ask your sales representative for more information

FEATURES

- Smooth CMY color mixing provides an infinite palette of color
- 2 fully rotating, fully indexable litho wheels each feature 5 replaceable lithos or effects and 1 fixed open position
- Variable frost
- Variable iris
- Variable strobe—can dim while strobing
- Remote focus
- Standard 18° lens
- Optional Wide and Narrow Angle lens (wide angle: 30°; narrow angle: 13°)
- LithoPatterns[®] high resolution glass gobos deliver customizable, near photo-quality image projection
- Full optical dimming and fade to black
- Optical encoders automatically correct the head's position if manually moved

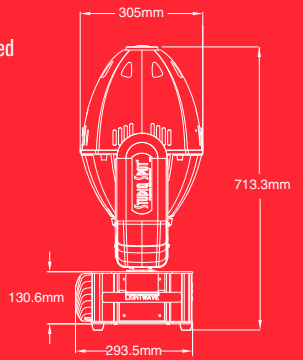
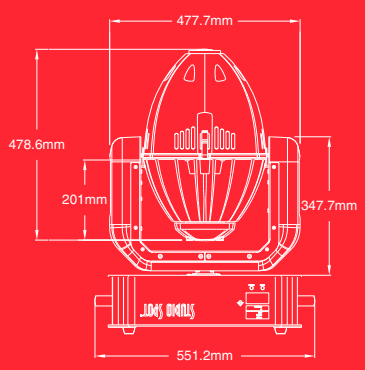

OPERATION

- 370° pan and 255° tilt movement
- Operates on 24 DMX channels in standard protocol
- Power Consumption: 750 W max; 100V – 240V, 50/60Hz
- Auto-switching power supply

CONSTRUCTION

- High resolution microstepping motor control for smooth motion at all speeds
- Stunningly fast, smooth, and quiet yoke movement using proprietary multi-phase technology
- Computer designed optical components for maximum light efficiency
- Convection cooled for quiet, fanless operation via integrated heatsink and reflector combination

OPTIONS

- Wide and Narrow Angle lens (wide angle: 30°; narrow angle: 13°)
- MSD 575 lamp (for enhanced lamp life)

MECHANICAL SPECIFICATIONS

- Height: 713.3mm (28 in.)
- Width: 551.2mm (21.7 in.)
- Depth: 305mm (12 in.)
- Weight: 26.76kg (59 lbs.)

HIGH END SYSTEMS



HIGH END SYSTEMS, INC.
 2105 Gracy Farms Lane
 Austin, Texas 78758 USA
 sales@highend.com
 www.highend.com

Austin: 1.512.836.2242
 Los Angeles: 1.818.947.0550
 New York: 1.212.957.6840
 London: 44.20.8579.5665
 Singapore: 65.6742.8266
 Orlando: 1.407.296.3359

©2003 High End Systems, Inc.
 All specifications subject to change without notice. 111203



Source: MSR 575/2
Output: 9,000 lumens
Color temp: 6200° K
Life: 500-750 hours

Source: MSD 575
Output: 7,500 lumens
Color temp: 5600° K
Life: 2,000 hours

