

INSTRUCTION MANUAL

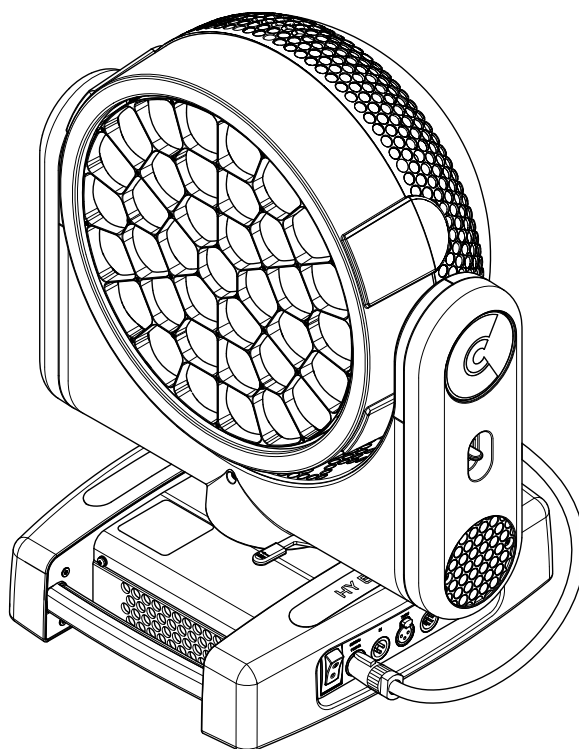

INDEX

Page	Contents
2	1. Safety information
3	2. Unpacking and preparation
4	3. Installation and start-up
4	3.1 Installing the fixture
4	3.2 Connecting to mains supply
5	3.3 Connecting the control signal line: DMX / Art-Net
5	3.4 Switching on the fixture and basic SetUp
7	4. Maintenance
7	4.1 Maintenance and Caution
8	4.2 Battery removal
9	4.3 Opening the covers
10	5. Specifications
11	6. Cause and solution of problems

Congratulations on choosing a Claypaky product!

We thank you for your custom.

Please note that this product, as all the others in the rich Claypaky range, has been designed and made with total quality to ensure excellent performance and best meet your expectations and requirements.

1. SAFETY INFORMATION

EN

SAFETY INFORMATION

IMPORTANT: Claypaky recommends you carefully read and keep the safety information on this product, also available in digital format at the following link:

www.claypaky.com

Ref: [FIS01I - Safety Information HY B-EYE series]

IT

INFORMAZIONI DI SICUREZZA

IMPORTANTE: Claypaky raccomanda di leggere accuratamente e conservare le informazioni di sicurezza relative a questo prodotto, sempre reperibili in versione digitale al seguente link:

www.claypaky.com

Rif: [FIS01I - Safety Information HY B-EYE series]

DE

INFORMATIONEN ZUR SICHERHEIT

WICHTIG: Claypaky empfiehlt, die Sicherheitsinformationen bezüglich dieses Produkts genau zu lesen und aufzubewahren. Sie sind in Digitalversion immer unter folgendem Link auffindbar:

www.claypaky.com

Ref: [FIS01I - Safety Information HY B-EYE series]

ES

INFORMACIONES DE SEGURIDAD

IMPORTANTE: Claypaky recomienda leer detenidamente y conservar la información de seguridad relativa a este producto. Además, está disponible una versión digital de la misma en el siguiente enlace:

www.claypaky.com

Ref: [FIS01I - Safety Information HY B-EYE series]

FR

CONSIGNES DE SÉCURITÉ

IMPORTANT: Claypaky recommande de lire attentivement et de conserver les informations de sécurité relatives à ce produit, disponibles en version digitale au lien suivant:

www.claypaky.com

Réf. : [FIS01I - Safety Information HY B-EYE series]

RU

ИНСТРУКЦИЮ ПО ТЕХНИКЕ БЕЗОПАСНОСТИ

ВАЖНО: Claypaky рекомендует внимательно прочитать и сохранить инструкцию по технике безопасности данного изделия, которая всегда доступна в электронном формате по следующей ссылке:

www.claypaky.com

Наименование: [FIS01I - Safety Information HY B-EYE series]

2. UNPACKING AND PREPARATION

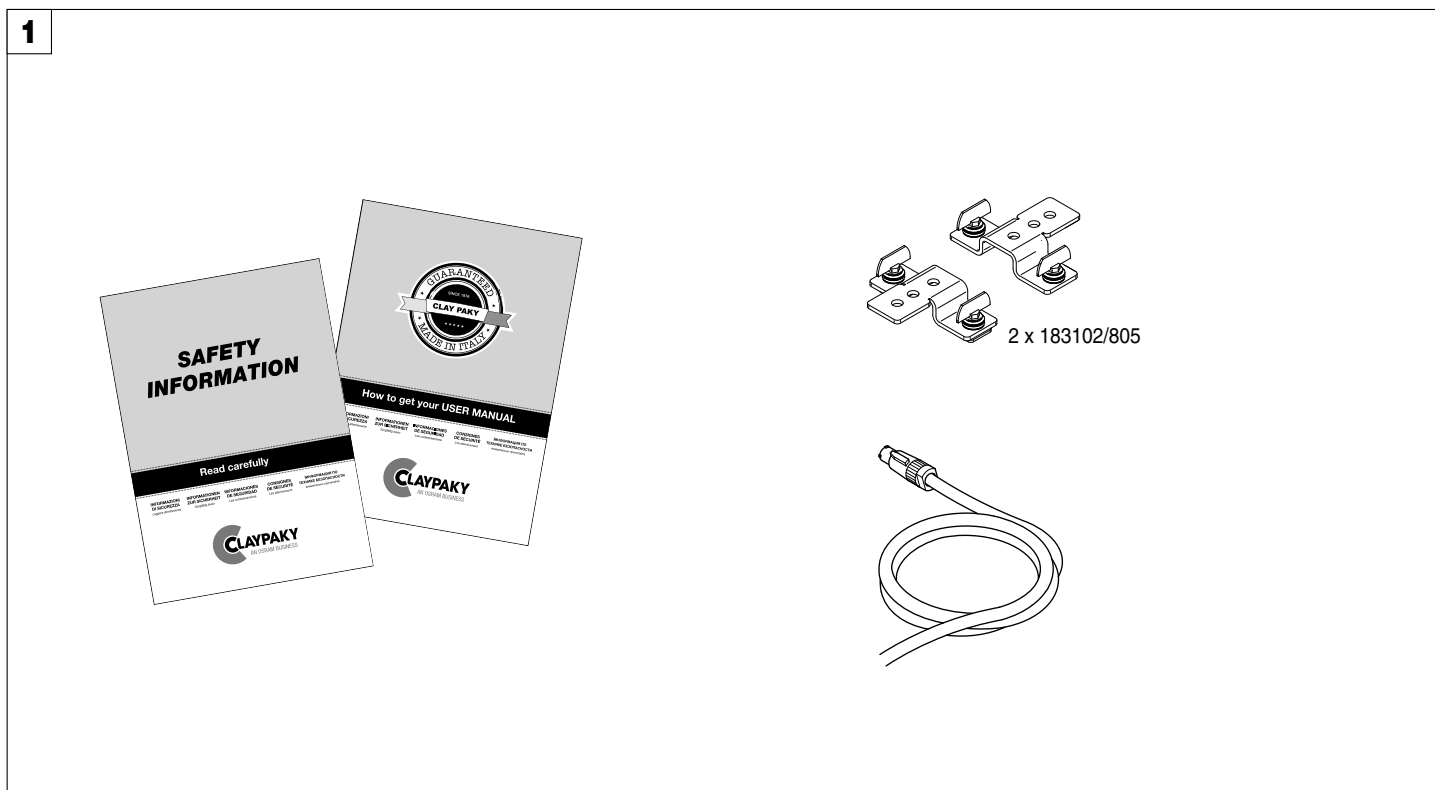

Packing contents - Fig. 1

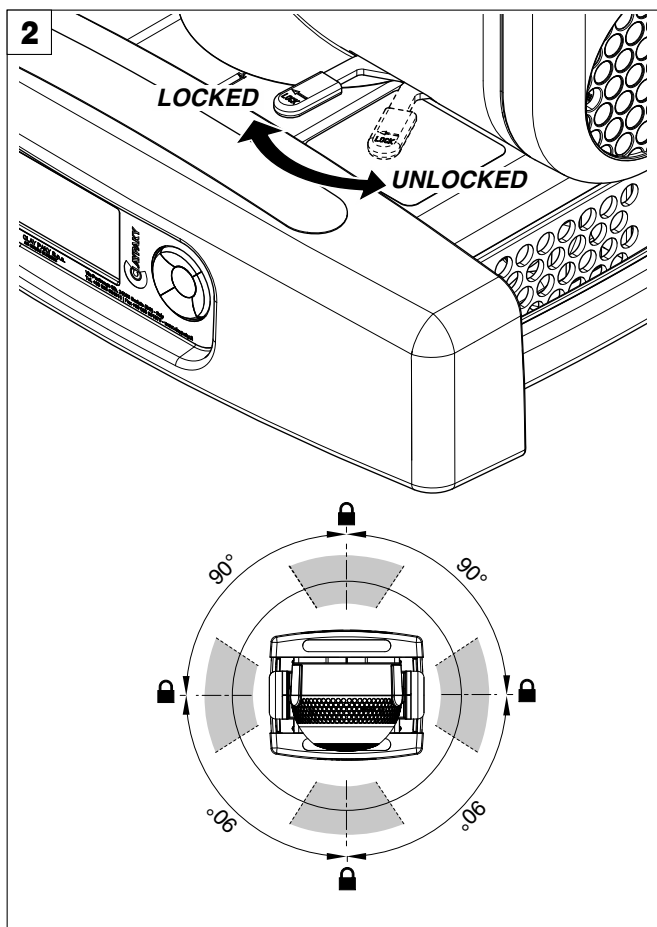

PAN Mechanism Lock and Release (every 90°) - Fig. 2

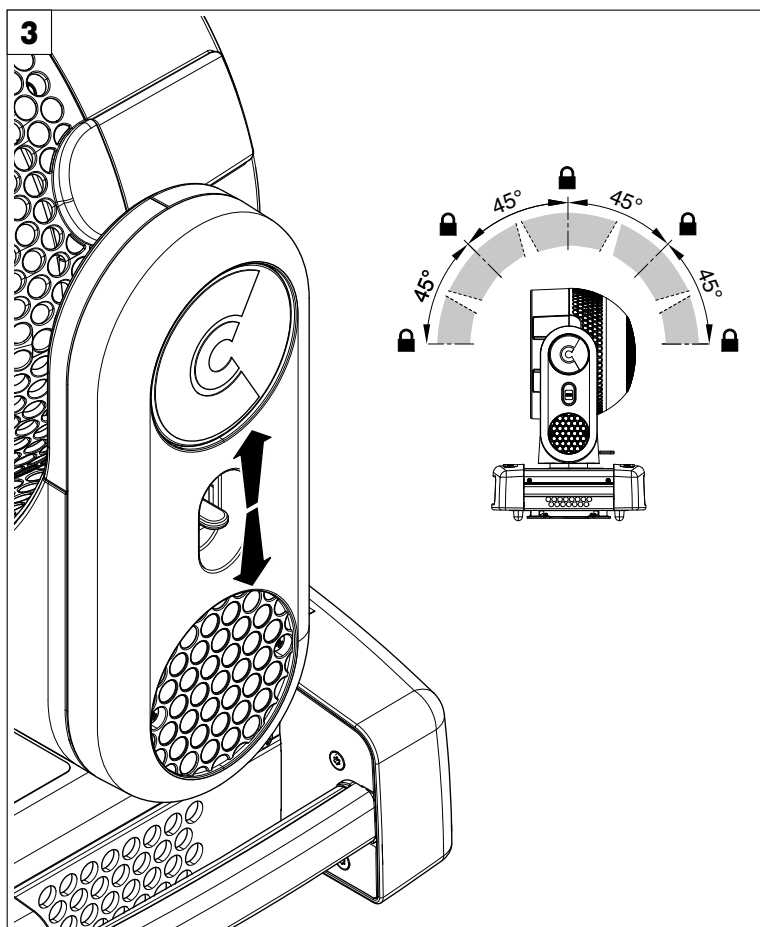

TILT Mechanism Lock and Release (every 45°) - Fig. 3

3. INSTALLATION AND START-UP

3.1 Installing the fixture

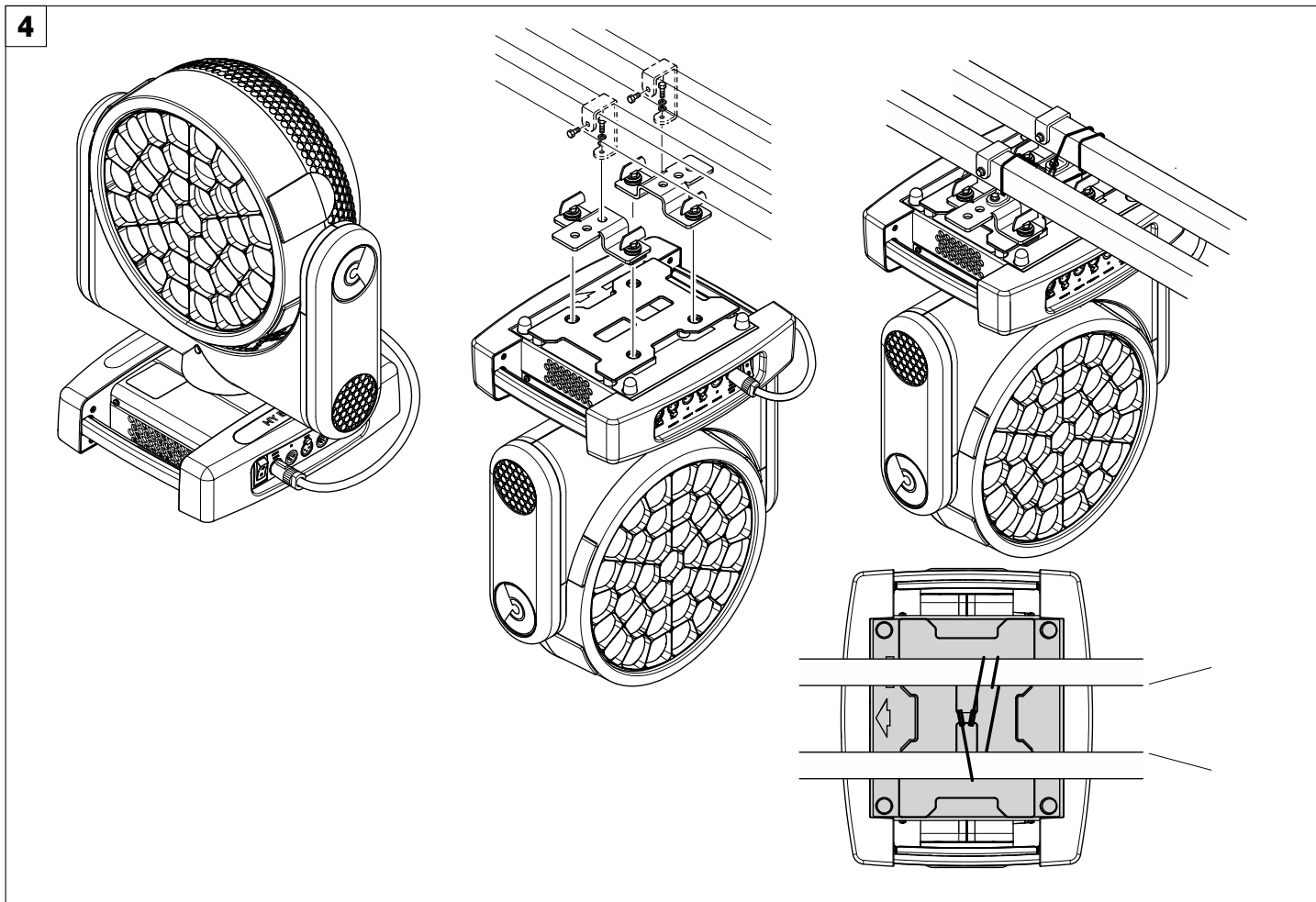

Installing the projector - Fig. 4

The projector can be installed on the floor resting on special rubber feet, on a truss or on the ceiling or wall.

WARNING: with the exception of when the projector is positioned on the floor, the safety cable must be fitted. (Cod. 105041/003 available on request). This must be securely fixed to the support structure of the projector and then connected to the fixing point at the centre of the base.

3.2 Connecting to mains supply

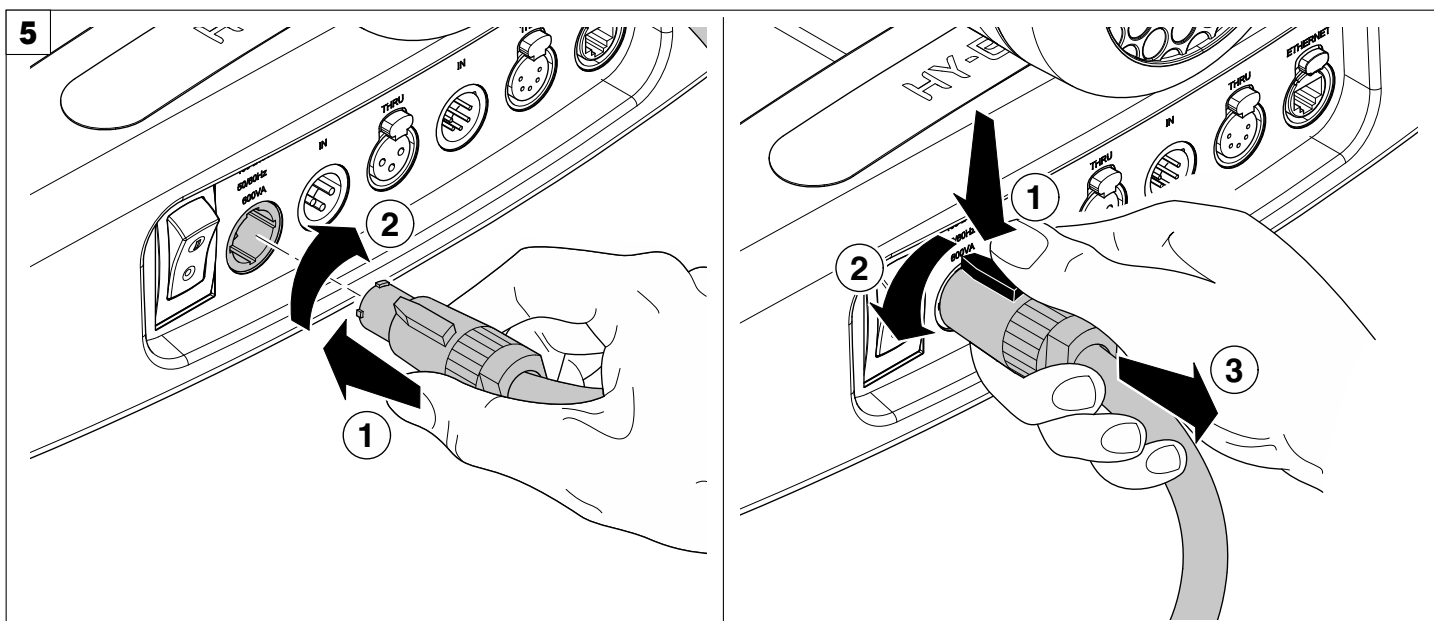

Connecting and disconnecting power cable - Fig. 5

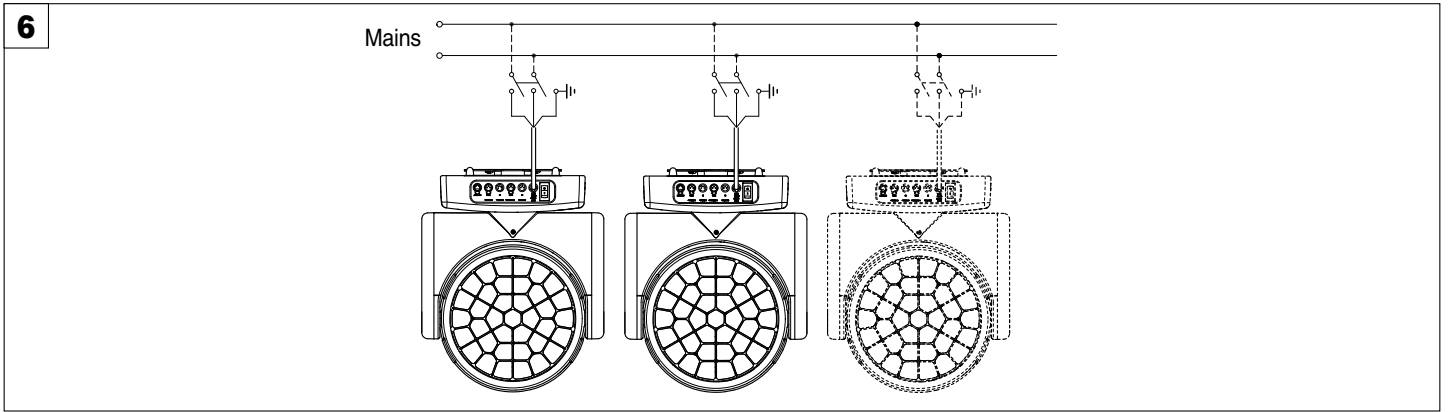

Connecting to the mains supply - Fig. 6

3.3 Connecting the control signal line: DMX / Art-Net

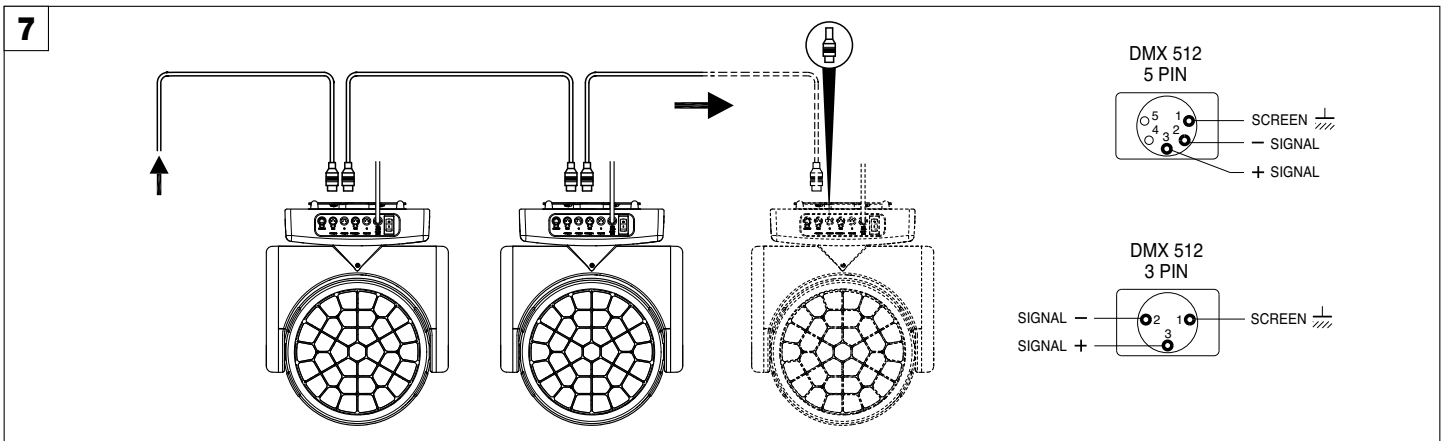

Connecting to the control signal line (DMX) - Fig. 7

Use a cable conforming to specifications EIA RS-485: 2-pole twisted, shielded, 120Ohm characteristic impedance, 22-24 AWG, low capacity. Do not use microphone cable or other cable with characteristics differing from those specified. The end connections must be made using XLR type 3/5-pin male/female connectors. A terminating plug must be inserted into the last projector with a resistance of 120Ohm (minimum 1/4 W) between terminals 2 and 3.

IMPORTANT: The wires must not make contact with each other or with the metal casing of the connectors. The casing itself must be connected to the shield braid and to pin 1 of the connectors.

3.4 Switching on the fixture and basic SetUp

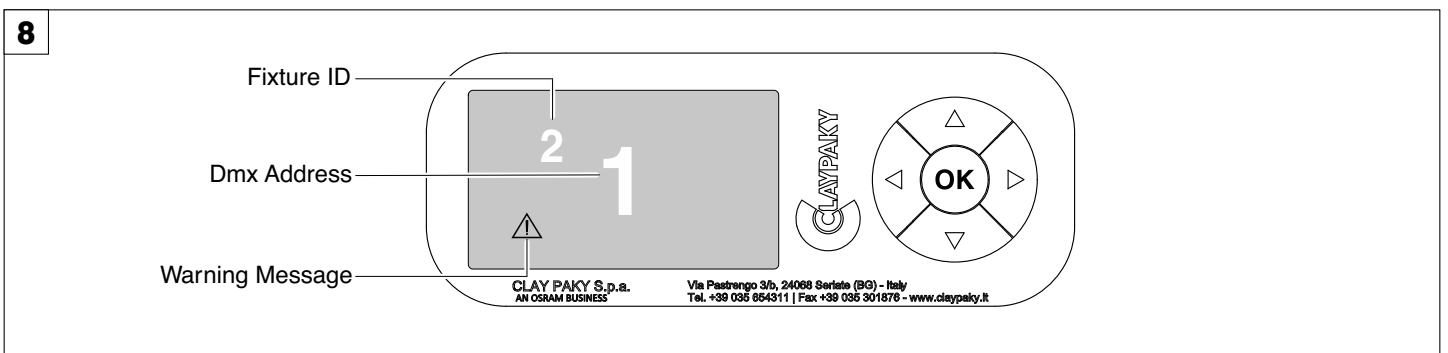

Switching on the projector - Fig. 8

Press the switch. The projector starts resetting the effects. At the same time, the following information scrolls on the display:



Model
HY B-EYE
K25 TEATRO

Firmware
Version X.X.X
Date - Hour

xxx (Fixture ID)
Dmx Address xxx

System errors
E:
W:

On conclusion of resetting in case of absence of the dmX signal, Pan and Tilt move to the "Home" position (Pan 128 bit - Tilt 128 bit). The control panel (Fig. 8) has a display and buttons for the complete programming and management of the projector menu. The display can be in one of two conditions: rest status and setting status. When it is in the rest status, the display shows the projector's DMX address and the Fixture ID address (if set).

During menu setting status, after a wait time (about 30 seconds) without any key having been pressed, the display automatically returns to rest status. It should be noted that when this condition occurs, any possible value that has been modified but not yet confirmed with the **OK** key will be cancelled.

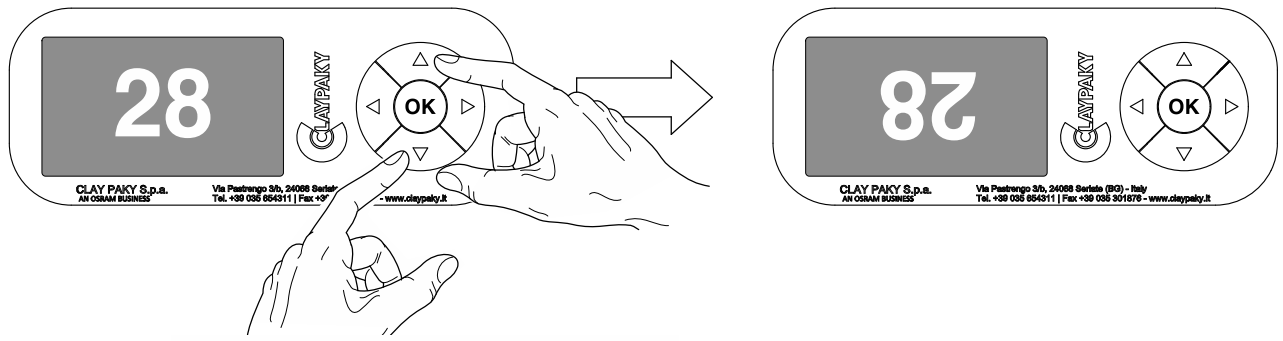

Reversal of the display - Fig. 9

To activate this function, press UP ▲ and DOWN ▼ keys simultaneously while the display is in the rest mode. This status will be memorised and maintained even for the next time it will be switched on. To return to the initial state, repeat the operation all over again.

Setting the projector starting address

On each projector, the starting address must be set for the control signal (addresses from 1 to 512).

The address can also be set with the projector switched off.

Setting the projector Fixture ID

On each projector, the Fixture ID address must be set for an easy identification of the fixtures in an installation (ID from 1 to 255).

The Fixture ID address can be set with the projector switched off.

Functions of the buttons - Using the menu

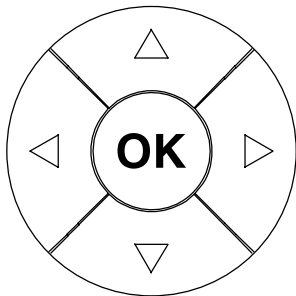

Confirms the displayed value, or activates the displayed function, or enters the successive menu.



DOWN

Decreases the value displayed (with auto-repetitions) or passes to the next item in the menu.



UP

Increases the value displayed (with auto-repetitions) or passes to the previous item in a menu.



LEFT

Return to the top level.



RIGHT

Commute from units, tens, hundreds, in the "Address", "Fixture ID" and "Calibration" menu.

USING THE MENU:

- 1) Press **OK** once – "Main Menu" appears on the display.
- 2) Use the UP ▲ and DOWN ▼ keys to select the menu to be used:
 - Setup (Setup Menu): To set the setting options.
 - Option (Option Menu): To set the operating options
 - Informations (Informations Menu): To read the counters, software version and other information.
 - Manual Control (Manual control Menu): To trigger the test and manual control functions.
 - Test (Test Menu): To check the proper functioning of effects
 - Advanced (Advanced Menu): Access to the "Advanced menu" is recommended for a trained technical personnel.
- 3) Press **OK** to display the first item in the selected menu.
- 4) Use the UP ▲ and DOWN ▼ keys to select the MENU items.

Setting addresses and options with the projector disconnected

The projector's DMX address, as well as other possible operating options, can also be set when the appliance is disconnected from the electricity supply. All that is needed is to press **OK** to momentarily activate the display and thus access the settings. Once the required operations have been carried out, the display will switch off again after a wait time of 30 seconds.

4. MAINTENANCE

4.1 Maintenance and Caution

10

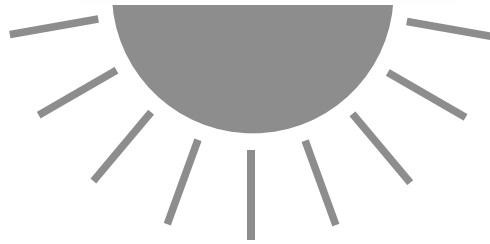

Light collimation system

This product contains internal light collimation system. Avoid intense light from any angle.

WARNING:
no alcohol

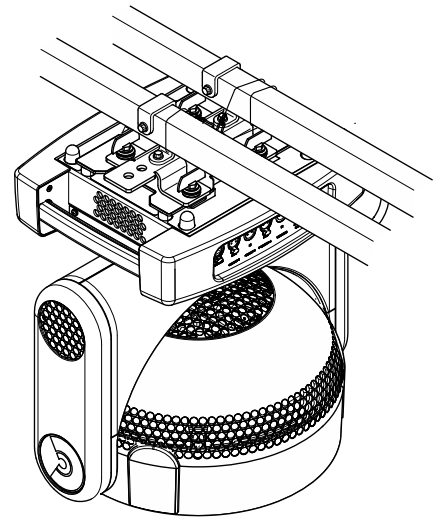
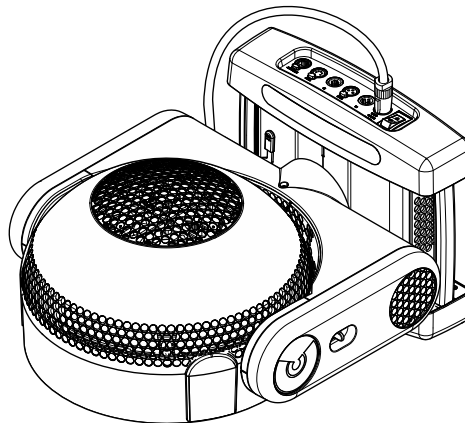
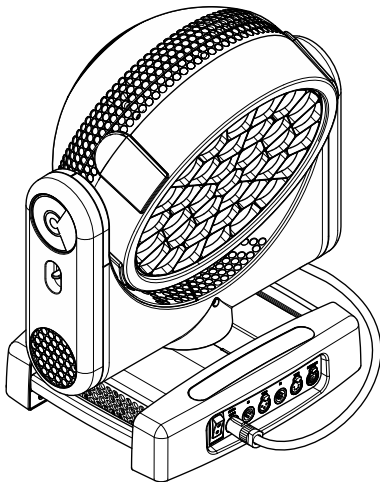
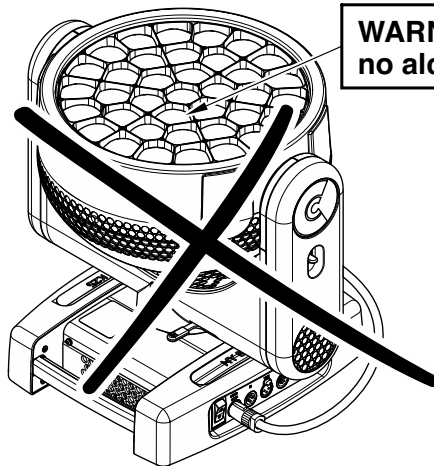

CAUTION:

- To avoid damage to the internal parts of the fixture when the fixture is not working, it is recommended to turn the head down before turning the fixture off, so that the front lenses of the fixture are invested as little as possible from the sun.
- Set Zoom channel to 255-bit before turning off the projector to facilitate the packaging of the projector.
- It is recommended not to use compressed air with more than 4 atmospheres for cleaning the internal parts of the fixture, led board area. This is to avoid damaging electronic components.
- To ensure optimal operation and performance for a long time it is essential to periodically clean the parts subject to dust and grease deposits. The frequency with which the following operations are to be carried out depends on various factors, such as the amount of the effects and the quality of the working environment (air humidity, presence of dust, salinity, etc.). It is recommended that the projector undergoes an annual service by a qualified technician for special maintenance involving at least the following operations:
 - General cleaning of internal parts.
 - Restoring lubrication of all parts subject to friction, using lubricants specifically supplied by Claypaky.
 - General visual check of the internal components, cabling, mechanical parts, etc.
 - Electrical, photometric and functional checks; eventual repairs.

Cleaning the lenses

Only use neutral soap and water to clean the lenses, then dry it carefully with a soft, non-abrasive cloth. (WARNING: the use of alcohol or any other detergent could damage the lenses).

4.2 Battery removal

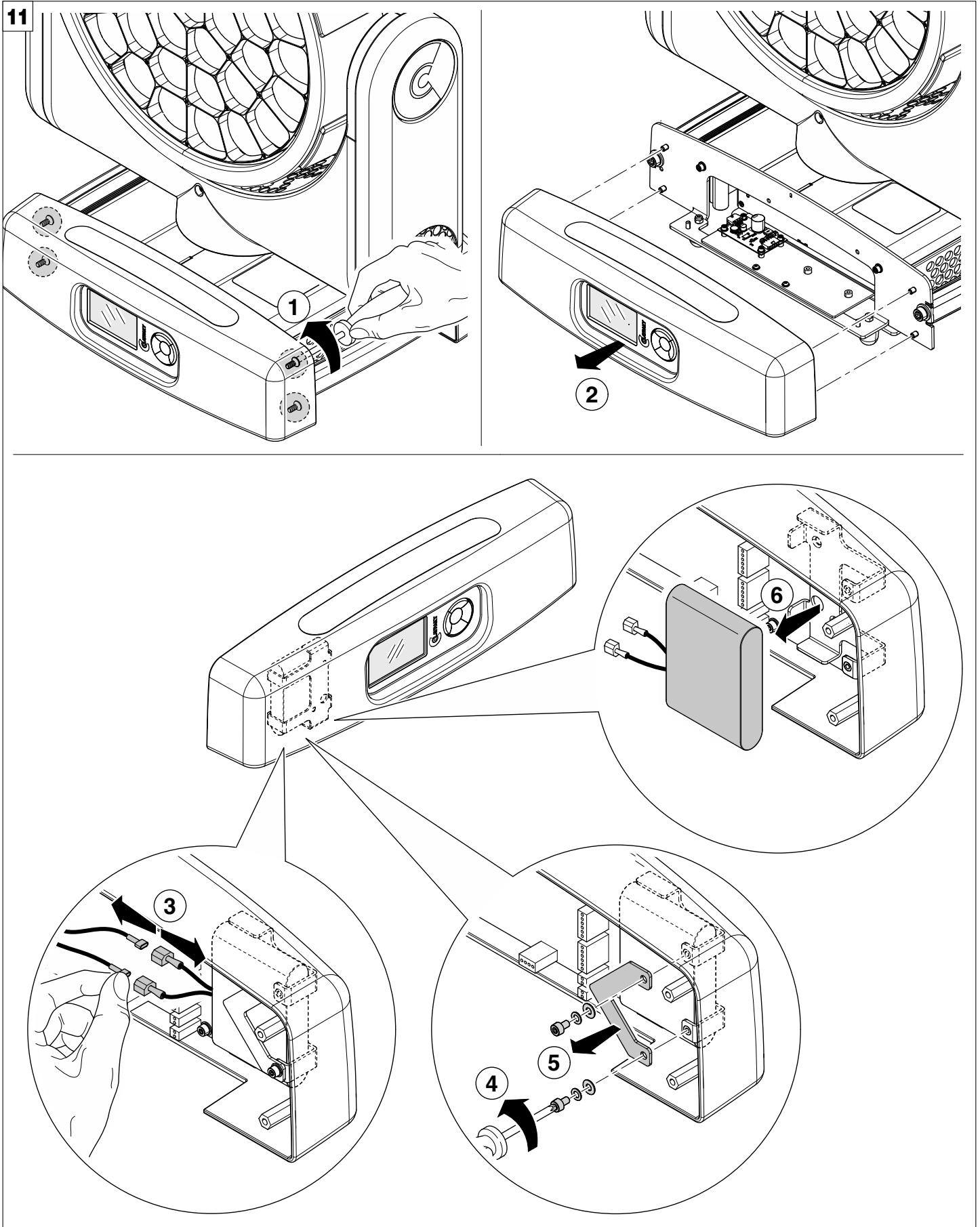

Battery removal - Fig. 11



This product contains a rechargeable battery. To preserve the environment, please dispose the battery at the end of its life according to the regulation in force.

4.3 Opening the covers

12

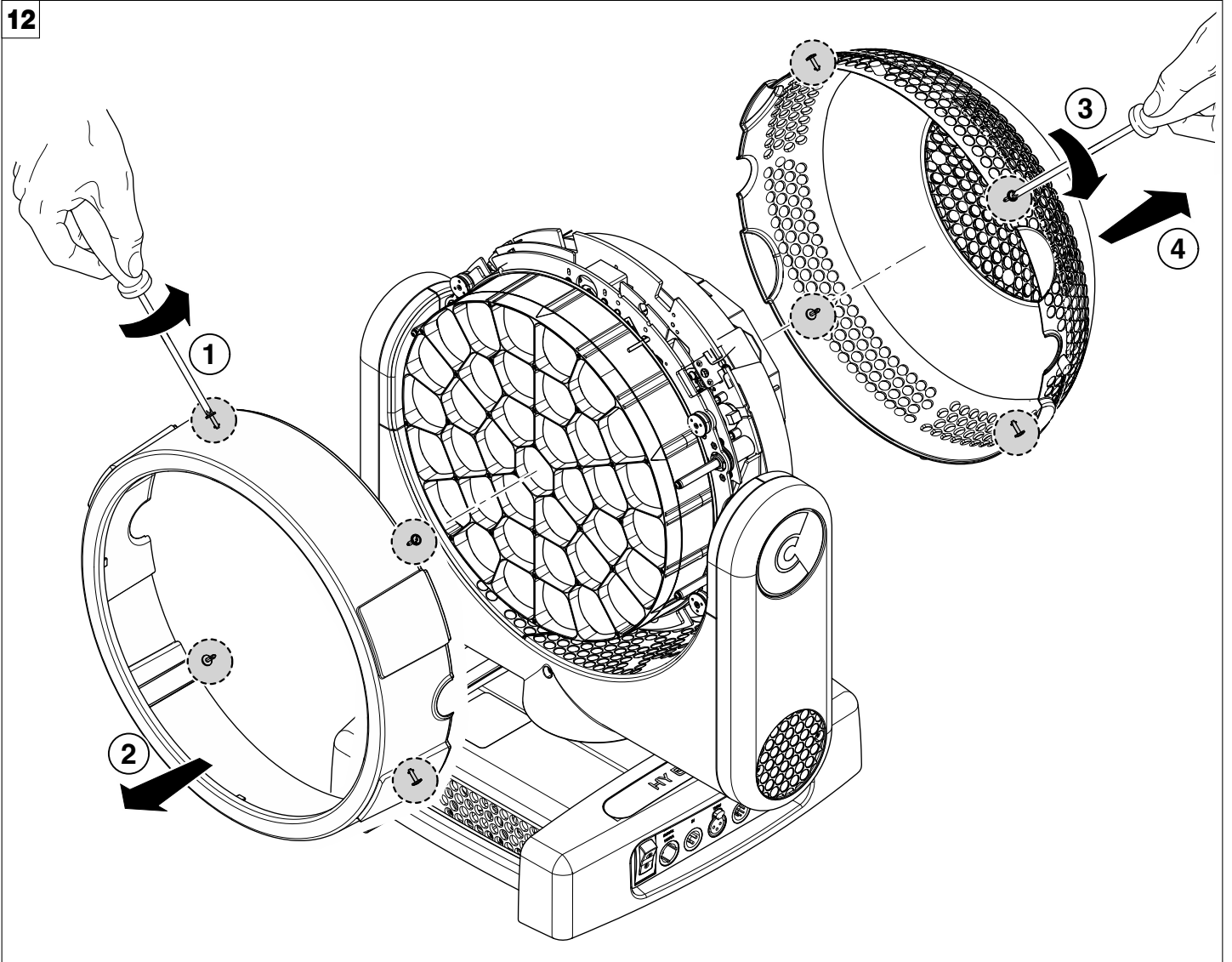

Opening the covers - Fig. 12

5. SPECIFICATIONS

HY B-EYE K25

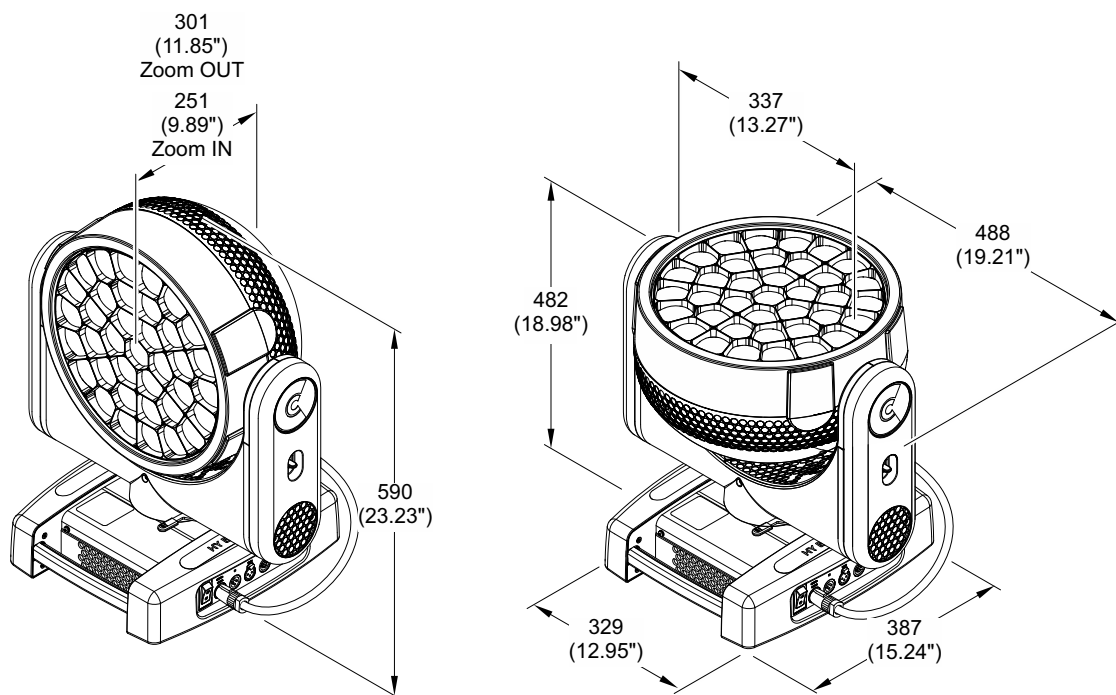

POWER SUPPLIES

100-240V 50/60Hz

INPUT POWER

1250 VA @230Vac - 50Hz.

LIGHT SOURCE

37 RGBW LEDs driven at 40 Watt
 Type: OSRAM OSTAR - Stage II LE RTDUW S2WN
 Color Temperature: 6,000 K
 Life: 50,000 hrs

OPTICS

4°-60° Electronic Zoom Range

EFFECTS SECTION

- Three operating modes: wash, beam, FX (Kaleido effects)
- Bi-directional Rotating Front Lens
- Digital Wash-Beam Framing effect
- Beam edge softening control (in Wash mode)
- Pixel Patterning Macros with enhanced control
- 0-100% linear electronic dimmer
- Adjustable speed stop/strobe effect, with instantaneous blackout
- Dedicated channel for color temperature setting
- White CT Emulation 2500-8000K
- RGBW auto-tuning to lamp CT Emulation
- Tungsten Lamp Emulation
- Slow Strobe: 1 flash/sec; Fast Strobe: 25 flash/sec

CONTROL AND PROGRAMMING

- 22/36/111/148 DMX channels
- Basic Engine (Standard and Shape Mode)
- Pixel Engine (RGB and RGBW Mode)
- DMX protocol signal: USITT DMX 512
- Art-Net / RDM
- Arkaos Kling-Net protocol already included in the firmware
- Pan/Tilt Resolution: 16 bit
- Dimmer Resolution: 16 bit
- Movement control: vectorial
- DMX signal connection: 3 and 5 pole XLR input and output
- Software upload through DMX input

BODY

- Aluminum structure with die-cast plastic cover
- Two side handles for transportation
- PAN and TILT lock for transport and maintenance

IP RATING

IP 20 - Protected against the entry of solid bodies larger than 12mm (0.47"); No protection against the entry of liquids.

NOISE LEVEL

Min 35.0 dBA (background 32.5)

ELECTRONICS

- Long-life auto-charging buffer battery
- Preset color and graphic effect macros
- Function reset controllable from a central control unit
- Menu-driven internal self-test function
- Ethernet ready with RJ45 socket
- Display: backlit black-and-white graphic LCD display
- Electronic check-up of every single parameter with error alarm
- DMX level monitoring on each channel
- Automatic internal data transmission error diagnostics
- Firmware upgrade even when the unit is not connected to the power supply
- Firmware transfer from one light to another

MOTORS

Stepper motors, microprocessor controlled.

MOVING BODY

- Movement by means of two stepper motors, controlled by microprocessor
- Automatic repositioning of PAN and TILT after accidental movement not controlled by control unit
- Travel:
 - PAN = 540°
 - TILT = 210°

WORKING POSITION

- Working in any position.
- Hanging system: with fast-lock omega clamps (1/4 turn) on the base.
- Optional safety chain.

SAFETY DEVICES

- Automatic power safety derating in case of overheat of the LED board
- Forced ventilation

CE MARKING

In conformity with the European Directives:

- 2014/35/EU - Safety of electrical equipment supplied at low voltage (LVD).
- 2014/30/EU - Electromagnetic Compatibility (EMC).
- 2011/65/EU - Restriction of the use of certain hazardous substances (RoHS).
- 2009/125/EC - EcoDesign requirements for Energy-related Products (ErP).

ETL

This product is available, on demand, with cETLus Listed Mark.

PACKAGING

- Carton box + Polystyrene
- Carton box + Foam shell
- Flight case + Foam shell (2 position)

WEIGHT

27,5 Kg (60.6 lbs).

6. CAUSE AND SOLUTION OF PROBLEMS

THE PROJECTOR WILL NOT SWITCH ON			<i>PROBLEMS</i>
ELECTRONICS NON-OPERATIONAL			
DEFECTIVE PROJECTION			
REDUCED LUMINOSITY			
		<i>POSSIBLE CAUSES</i>	<i>CHECKS AND REMEDIES</i>
●		No mains supply.	Check the power supply voltage.
●	●	LED exhausted or defective.	Call an authorised technician.
	●	Signal transmission cable faulty or disconnected.	Replace the cables.
	●	Incorrect addressing.	Check addresses (see instructions).
	●	Fault in the electronic circuits.	Call an authorised technician.
	●	Lenses broken	Call an authorised technician.
	● ●	Dust or grease deposited.	Clean (see instructions).

